



Nepal Sanitation Studio 2013

The Studio included 8 architecture students and 4 plumbers who contributed their time and skills to work with a skilled team of local Nepali people to improve sanitation in rural Nepalese villages.

The Studio was supported by the International Association of Plumbing and Mechanical Officials (IAPMO), RMIT (Royal Melbourne Institute of Technology - Australia), the World Plumbing Council and the Worldskills Foundation.

The work of the Sanitation Program has been greatly assisted by donations from EgresStudio Newcastle (Australia) and two of the EgresStudio members attended the week's work.

The Nepal Sanitation Studio was hosted by Community Health and Development Society (Nepal), the participating villages and Healthabitat (Australia) as a part of the Nepal Village Sanitation Program.

Nepal Sanitation Studio : aims and introduction

The aim of the Studio was to work with the existing, skilled Nepalese team to develop the design process and construction detail of toilets to further improve health by the safe removal and treatment of human waste.

The visitors who participated in the Studio worked hard to develop the Nepal Village Sanitation Program. The Studio used their combined skills and enthusiasm to improve the existing Program and not displace, disrupt or discourage the local Nepalese teams. The Studio left significant improvements in both design and construction and these improvements will be used and replicated by the Nepalese teams in many future toilets. The hand tools left by the visiting plumbers with the Nepali team, were greatly appreciated.

From Community Health and Development Society (CHDS Nepal), the participating villages and Healthabitat (HH Australia) - our sincere thanks to all those that participated.



A brief history of the Nepal Sanitation Program

November 2006

CHDS and Rotary were invited to Bhattedande village, Kavre District, to discuss issues affecting the daily lives of the villagers. Water supply, lack of toilets, education, and income generation were identified as key priorities.

The Sree Tamang Village Environment Development Committee (STVEDC) was formed in Bhattedande, to work with CHDS, Rotary and Healthabitat to develop a toilet sanitation project.

April 2007

Healthabitat works with the villagers to plan the first stage of the sanitation project.

Discussions about the design of the toilet buildings, using a biogas digester or septic tank for waste management,

The need for water and collecting water from the toilet roof and storing the water in a tank for dip flushing and hand washing. Making an agreement about how the partners will work together.

Villagers access water at 10 tap points located throughout the village. The villagers gather water from these 10 taps twice a day when water is released from a header tank. They fill buckets and metal vessels and carry them back to their homes.

The local plumber and construction coordinator, work with Healthabitat to set up water quality testing. Water quality testing commenced and the local villagers trained to complete the testing regularly over 12 months.

Water meters also installed to measure average daily use from 3 of the 10 tap points located throughout the village.

Plumbing repairs and modifications were commenced on the first day of the project.

Since then, a reticulated water supply has been put into Bhattedande village.

The project partners agree to start Stage 1 of the toilet building project by constructing only two toilets, one with a biogas and one with a septic waste disposal system.

The project is managed by CHDS Nepal, using local labour and materials. This "trial" allows for all partners to gauge their ability to effectively work together, plus the villagers will have a chance to observe the process of construction, view the results, assess their appropriateness and apply any modifications if necessary for the continuation of the project.

A brief history of the Nepal Sanitation Program (cont)

July 2007

The project achieves accreditation with Rotary Australia World Community Services. Project number 66/2007-08. There is satisfaction with the two trial toilets and the project begins in earnest.

July 2007 - November 2010

A total of 58 toilets with either septic tank (38) or biogas (20) waste systems have been built in Bhattedande. Villagers have been instructed in toilet maintenance and regular hygiene including hand washing with soap. Two local women now have been trained to inspect and report any faults with the toilets as part of the ongoing maintenance.

April 2011

The project moves into two more Tamang villages, Arubot and Dandegaun. A skilled team developed from the Bhattedande project, and this team, in coordination with the management of the CHDS team, leads the project in the next two villages. Each village develops a local management committee whose members are encouraged to participate in the activities of the project, and some of whom have gained employment in the project.

The same methodology applies, that is, two trial toilets are built first in each village. Once approved, and with any design modifications, the project is rolled out in two stages each year, one before and one after the monsoon time. The target for these two villages combined is 100 toilets.

2012 and ongoing

Works continue

January February 2013

Sanitation Studio

Existing design information

The toilet building in context : the house, paths, biogas churn, biogas outlet point, tap point



Existing design information

The toilet building



1. 500 litre poly water tank
2. Base to tank (approx +300mm above floor level)
3. 2.5 x sheets of roofing iron
4. metal gutter, ends, spout and downpipe to tank
5. hardwood roof structure
6. hold down rods for roof in pier corners of the walls
7. brick walls
8. hard render external to approx 700mm from ground
9. hard render internal (+600 from floor level)
10. asian type pan
11. Ball valve for dip flush (inside)
12. Ball valve tap for hand washing (outside)
13. Insect meshed vents (front and side)
14. timber framed door with metal infill and slide bolt and handle (inside) and pad bolt and handle (outside)
15. coat / clothes hooks and cleaning brush and securing rope and fixings (not indicated on this drawing - see details)
16. Entry pathway of optional brick or stone
17. Splash pad and drain for hand wash tap
18. *connecting septic tank OR biogas tanks not indicated in this drawing*

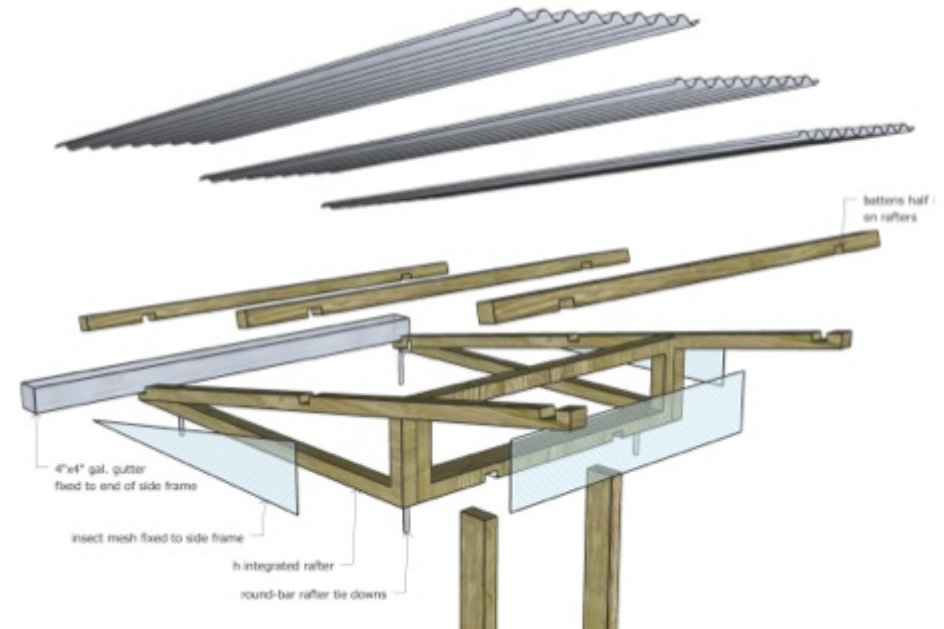
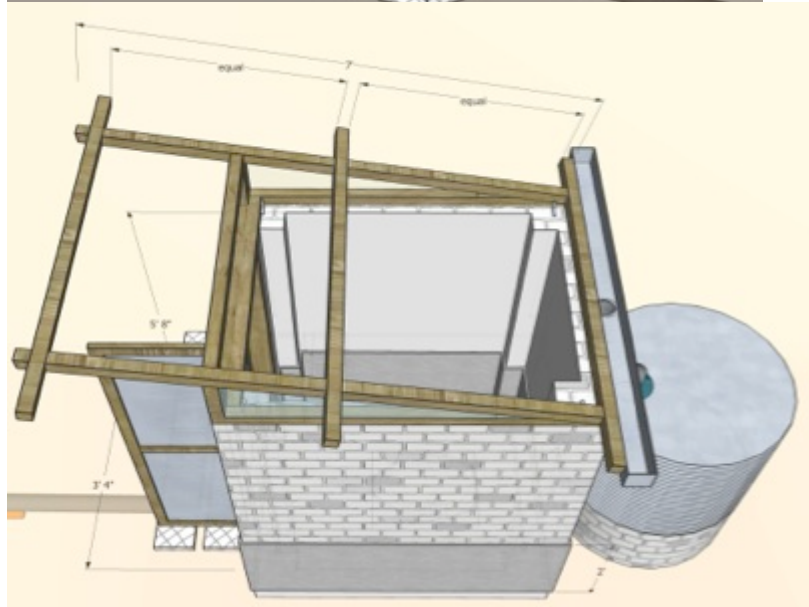

Existing design information

The toilet building (plan ideal layout)

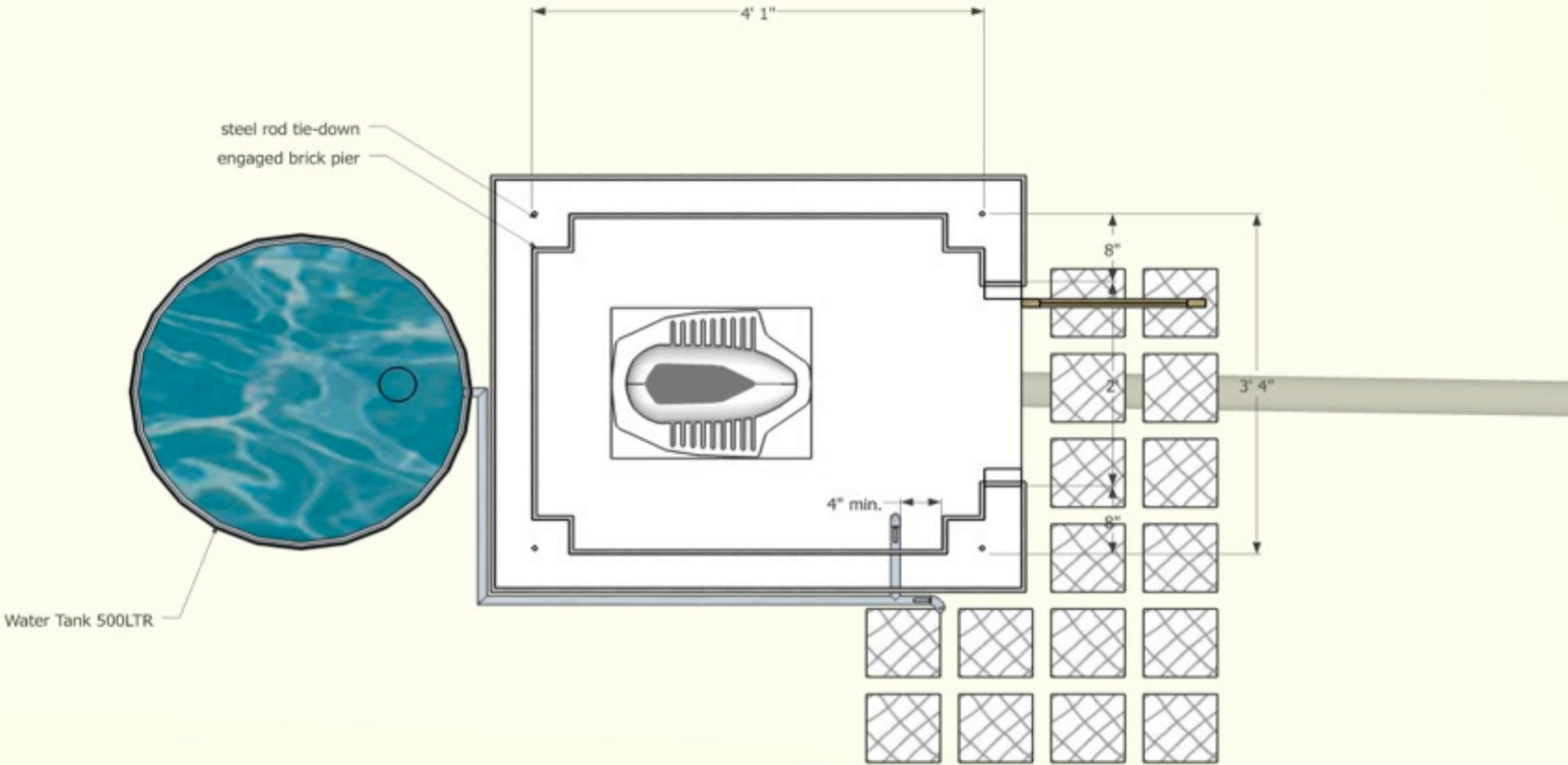

**Existing design
information**
The septic tank

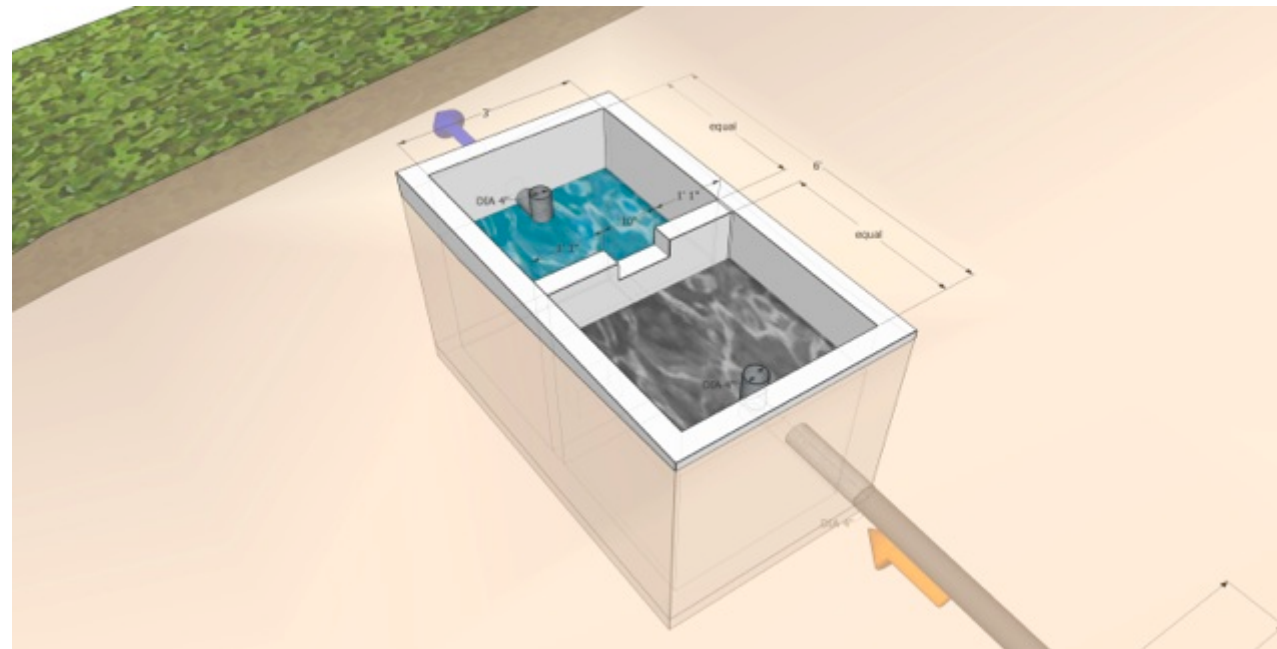
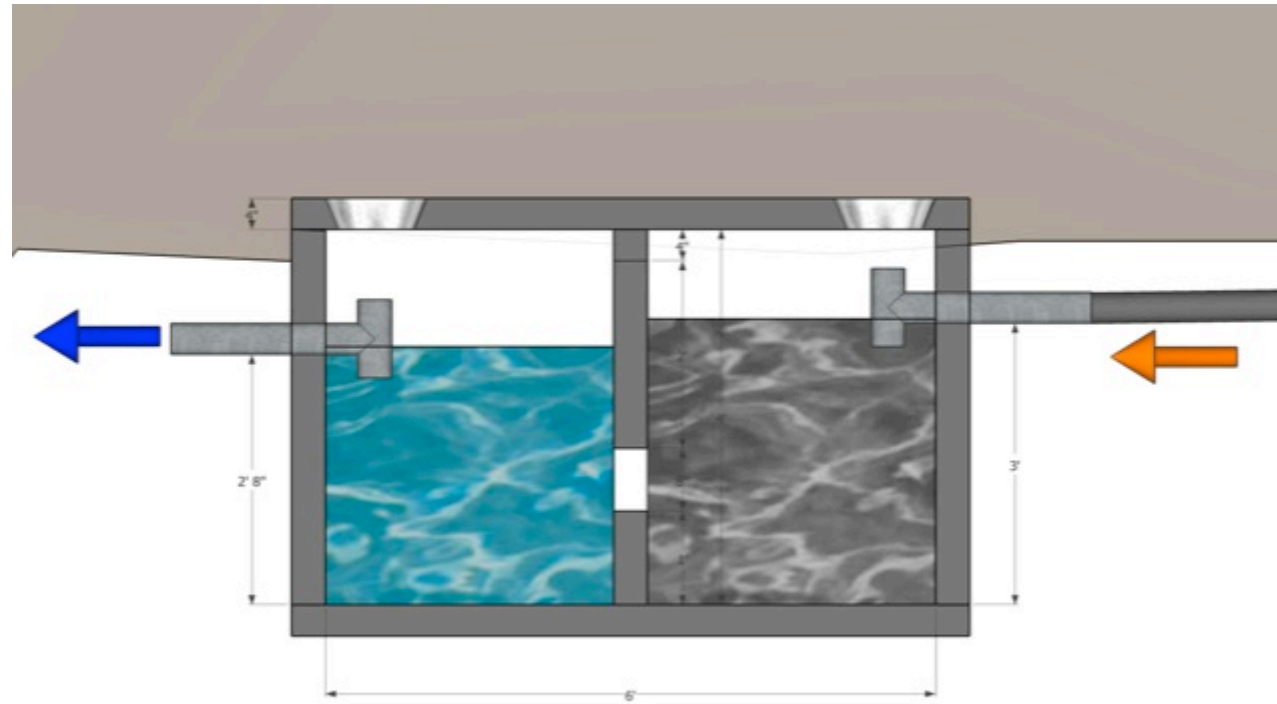

Existing design information

The toilet building and bio-gas plant (plan and section views)

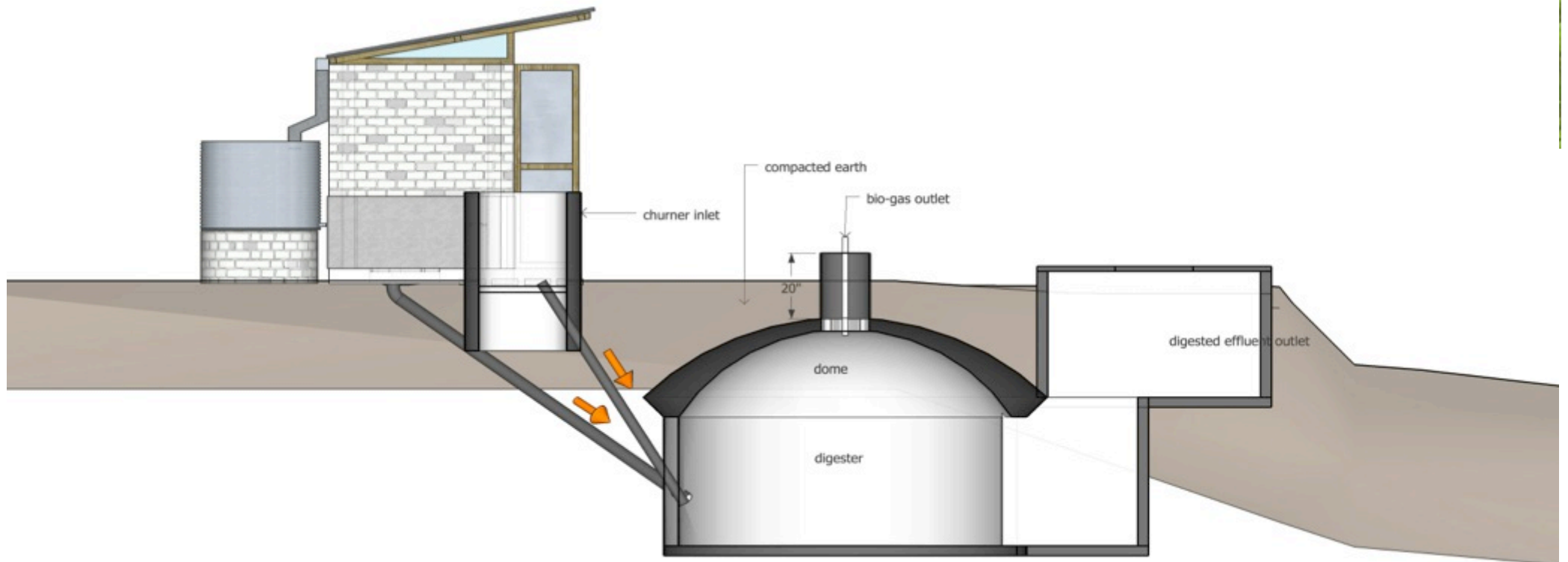
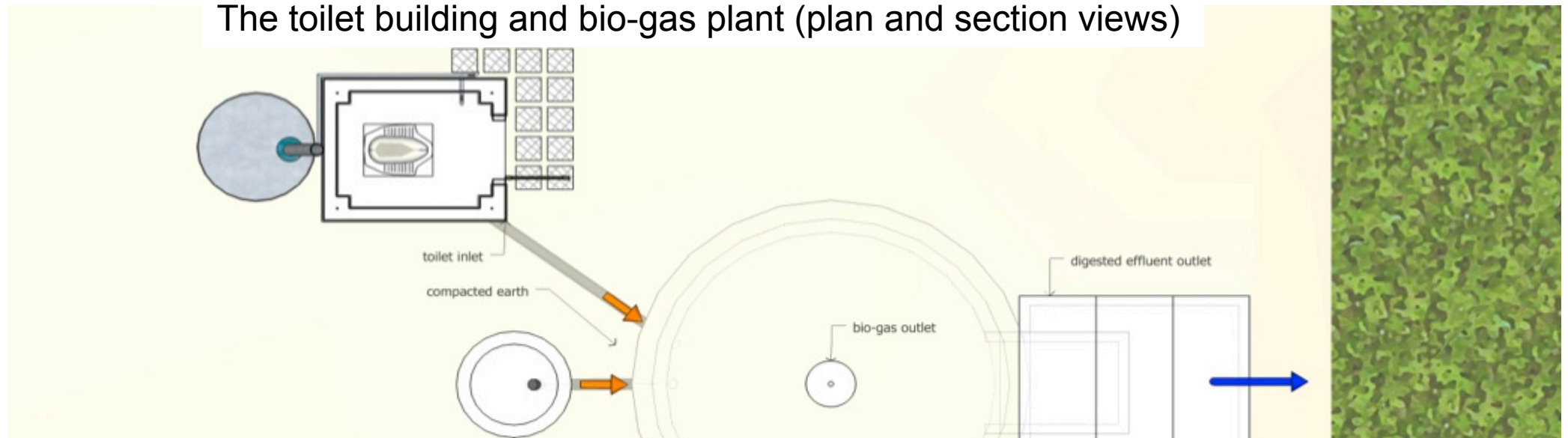

The Studio brief for the Plumbing Team

Improving the rainwater system –

to be reviewed, redesigned and rebuilt within the studio week. There are drawings and pictures of the existing design included in this brief.

Including:

- Tank and lid
- Gutter type and fixing
- Spout type and fixing
- Diverter for dry season roof dirt (preliminary ideas later in this brief)
- Tank filler option where water is available (preliminary ideas later)
- All taps and pipework
- Hand wash splash pad and drainage

Important considerations

Use local expertise and the local plumbing team (Surya Lama),

Use only locally available materials (HH and CHDS will help to find and buy them),

Leave behind at least one completed toilet (ie the new work has been installed and is working) with the new spec. and design documented so that is well understood by local plumbing team and can be reproduced.

Ask the archi-students to help document the design and spec. using pictures and drawings, not words.

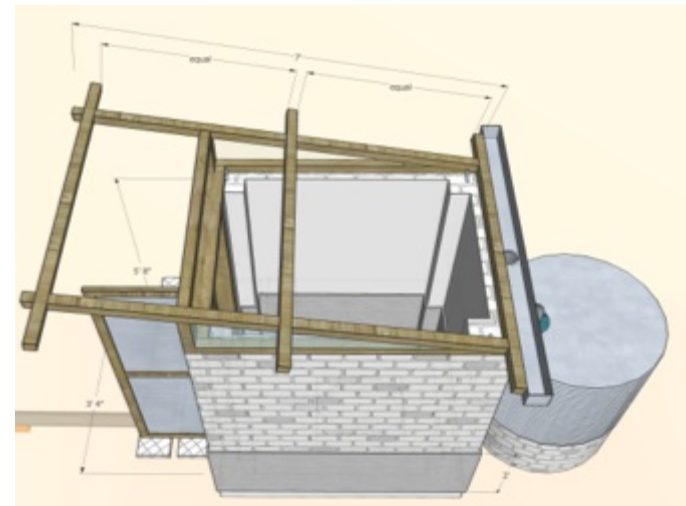

The Sanitation Studio plumbing brief

Preliminary ideas for the proposed diverter valve

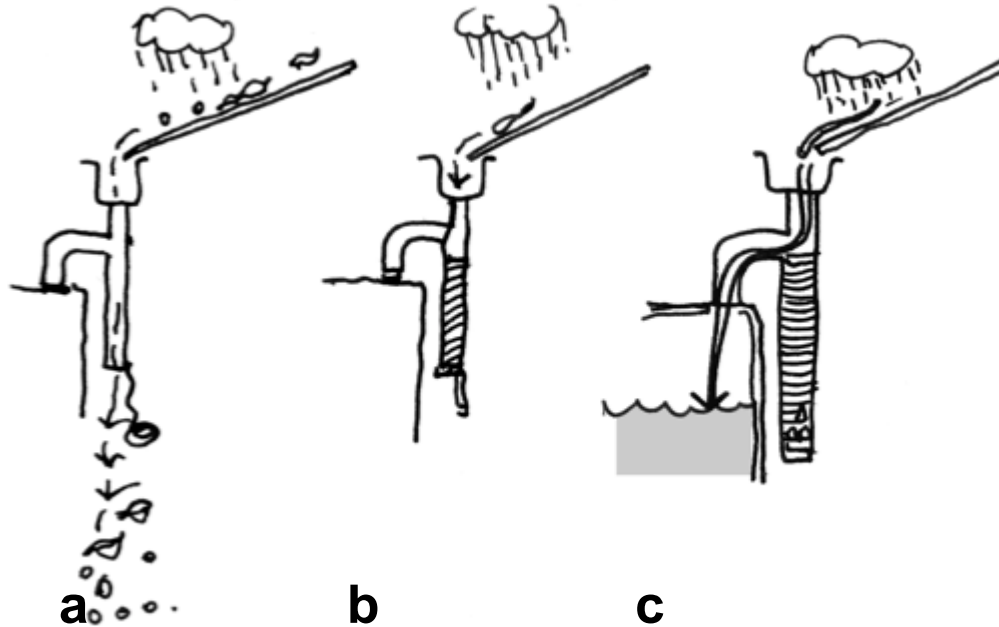

Function:

- During dry season stopper left open to allow rubbish to drop through open pipe
- After the first few storms that clean the roof, the stopper is fitted ... the next water will be diverted into the pipe (and can be drained later) How to not lose the stopper ?
- During the wet season when the roof is clean the stopper is secured to ensure all water is collected (it may be removed to drain any dirty water or rubbish at any time)

Notes:

- New metal spout from gutter will need to be round not tapered and fit into the plastic pipe
- The plastic pipe (?) will need to be screwed to the metal spout.
- Maybe a strainer can be incorporated?
- The plastic flange(?) to the tank top will need to be screwed to the pipe

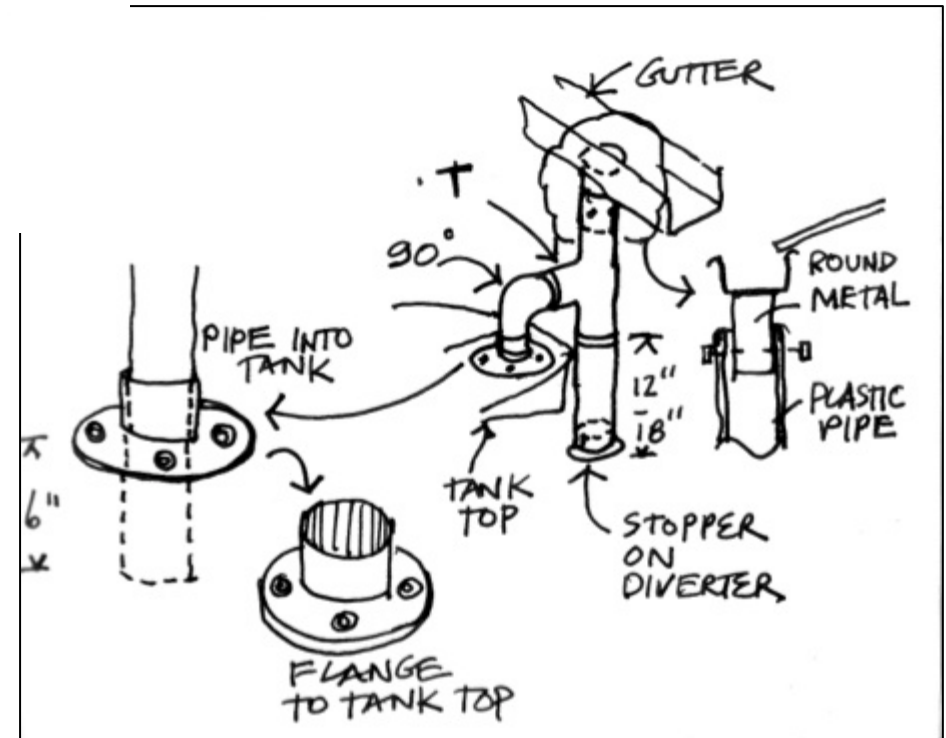

Summary of the solutions from the plumbing team

- 4 different diverter valve solutions were designed and constructed
- **Type A** with larger pipework and a simple hole to drain the diverted water
- **Type B** with larger pipework and a ball valve to drain the diverted water
- **Type C** with smaller, existing size pipework, this system was designed to be retro fitted to current systems and had a 45 degree diverter chamber with capped end and securing chain
- **Type D** with smaller existing size pipework, this system (similar to Type C) was designed to be retro fitted to current systems and had a 90 degree diverter chamber with capped end and securing chain

The 4 systems were designed, fabricated and installed with the local Nepali team to ensure the two way transfer of design detail and local knowledge about processes and materials. The systems will be evaluated after the mid-year wet season and the best options selected for future works.

- A simple and direct **tank filler point** was designed, fabricated and installed.
- A **wash pad** with integrated drainage for hand washing and general washing was designed and parts of the system were fabricated for future trial.

DETAILS OF ALL THE ABOVE DESIGNS FOLLOW



A B



Diverter options



C D

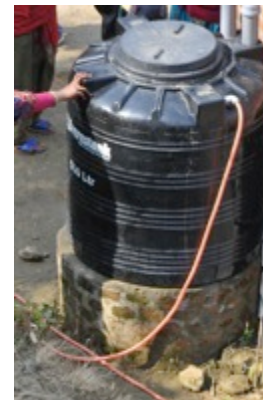

Tank filler point

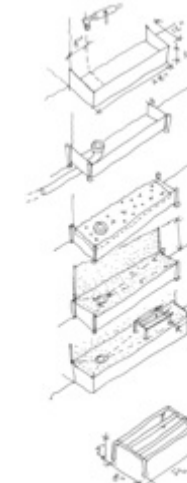

Wash pad design

Diverter Type A

Larger pipework, offset gutter spout and a hole in the diverted waste water pipe for drainage. (intended for all new works)



Diverter Type B

Larger pipework, offset gutter spout and a ball valve in the diverted waste water pipe for drainage.
(intended for all new works)



Detail of the fabrication and fitting: the gutter and spout



1 2



3 4



Detail of the fabrication and fitting: the gutter and spout



5
7



6
8



Detail of the fabrication and fitting: the completed gutter and spout



Detail of the fabrication and fitting: the pipework (for Types A and B)



Detail of the fabrication and fitting: the pipework (for Types A and B)



1 2



3 4



Detail of the fabrication and fitting: the pipework (for Types A and B)



5 6



7 8



Detail of the fabrication and fitting: the completed pipework for Types A (shown) and B



Detail of the fabrication and fitting: fitting the pipework (for Types A and B)



1 2



3 4



Type A diverter with drip pipe waste completed



Detail of the fabrication and fitting: fabricating the drain valve for Type B



1



2



3



4

Detail of the fabrication and fitting: fabricating the drain valve for Type B



5



6



7



8

Detail of the fabrication and fitting: the completed drain valve for Type B



Type B diverter, with valve, completed



Type C diverter: with 45° waste pipe, smaller pipework (to match existing) and central spout to enable retro-fitting onto existing systems (inset picture right)



Detail of the fabrication and fitting: Type C (similar tank and pipe work for Type D)



1
2



3



4



5

Type C diverter : completed with 45° waste pipe, smaller pipework (to match existing), central spout retro-fitted onto an existing system. NOTE the removable cap for cleaning and the chain to prevent loss.



Type D diverter : completed with 90° waste pipe, smaller pipework (to match existing), central spout retro-fitted onto an existing system. (similar to Type C) NOTE the removable cap for cleaning and the chain to prevent loss.



Preliminary suggested design idea for the water tank filler

Notes:

- Various sources of water supply in the village means people want to fill the toilet water tanks for general family use during the dry season using a hose
- Currently the tank lids are removed frequently and this causes damage

Preliminary idea -

- The new addition consists of:
 - a T piece near the tank outlet
 - 90 bend
 - length of gal. pipe strapped in 2 places to the brick wall of the toilet. Pipe diameter to be the same as pipe to taps
 - 90 bend
 - short piece of pipe to allow strapping
 - 90 bend turned out from wall
 - nozzle for hose attachment as per hand washing tap nozzle
- The main pipe should be at least 4" above the tank lid height to avoid syphoning of the tank water when filling

The Studio produced a simpler, easy to fabricate and cheaper design than the suggested idea.

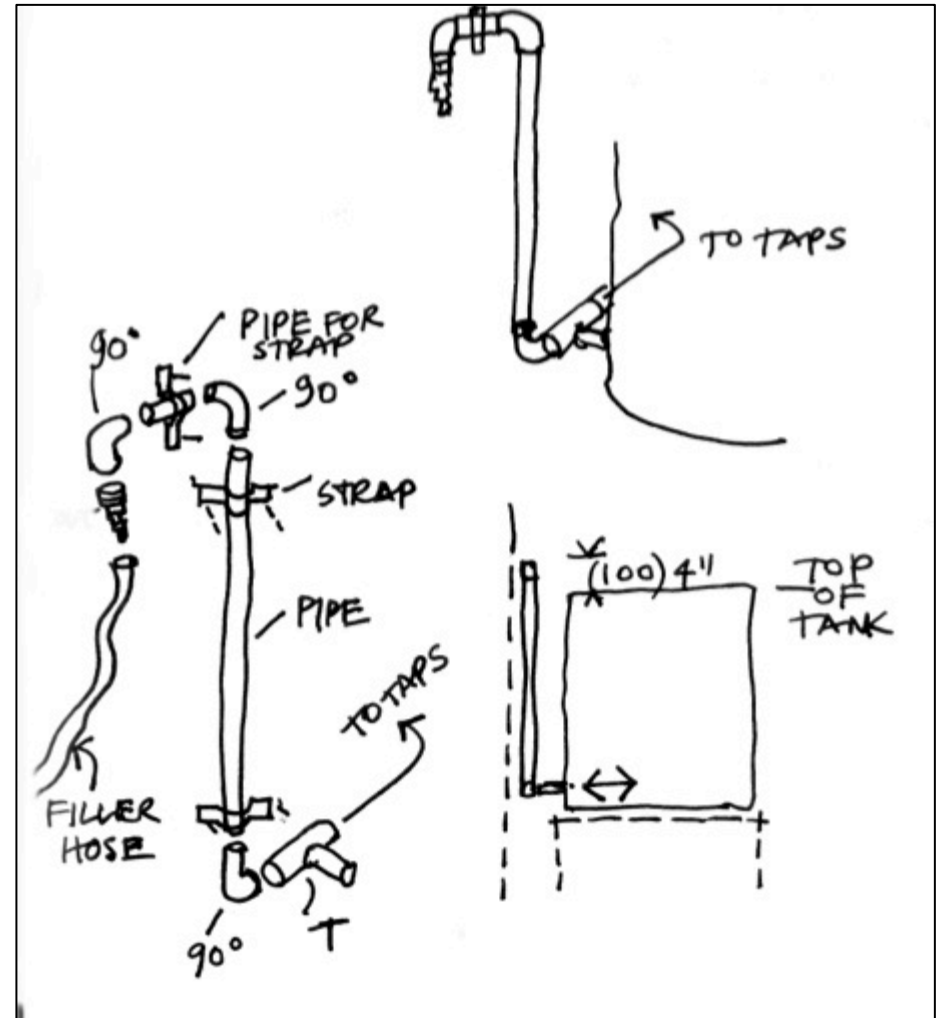

Water tank filler point : galvanised fitting inserted into the side flange of the water tank to protect the fitting and allow the fitting to easily be turned up or down for varying pipe entry angles



Wash pad and drain:

This informally designed and built wash pad shows the need for a standard design and construction method. The drain is small, the falls are different on each toilet and hand washing after toilet use can conflict with utensil cleaning.



Preliminary design for the wash pad design and construction

Steel form for forming concrete pad
(24"x 12"x 4"high x minimum 1/8th thick)

Formwork pegged to toilet wall and (50mm) 2" drain pipe set into form and centered under the tap

Concrete poured into under drain flange

Hard render up wall and over concrete pad ... all falling to drain

Wash stand embedded into hard render, when set – steel form removed for re-use

Wash stand 1/4 " reinforcing bar (this was fabricated and shown to village families for comment)

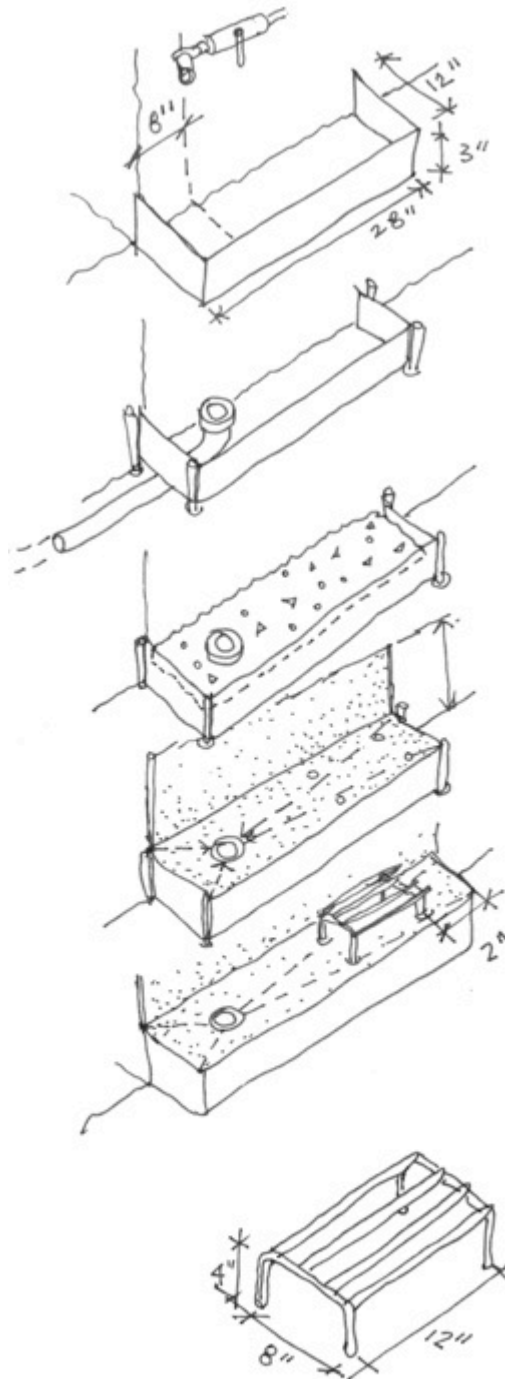

For brief for the architectural student team

Improving the toilet design, siting and detail

Siting kit: Currently a local engineer checks the siting of each toilet and waste system for structural safety. This will continue to be done. Your kit of parts, with minimal if any written instructions, will be designed for our Nepali team to use when siting toilets with each family. The kit should be designed, manufactured, packaged and tested within the studio week. The kit should consider:

- Toilet building location and size
 - The engineers criteria
 - Proximity to other buildings and terrace edges
 - Entry and door swing
 - Hand wash location relative to toilet and drainage
 - Septic or biogas location, size and connections to toilet, house and drainage areas
 - Paths, access, privacy
 - Winds and rain
 - Land (ownership, topography, drainage)
-
- A **better door** and / or personalising the door (kids project?)
 - Designing a better **hand washing point** and splash pad
 - Find higher quality / robust **toilet brush (and rethink a better attachment), clothes hooks and toothbrush storage**
 - **Better documentation of the toilet building** for the construction teams.

By all means, get involved with the plumbing team, as this will help your work. You may be able to help them with communication of their design ideas and their design work, but remember, your focus is on the above projects.



The current toilet and septic tank components

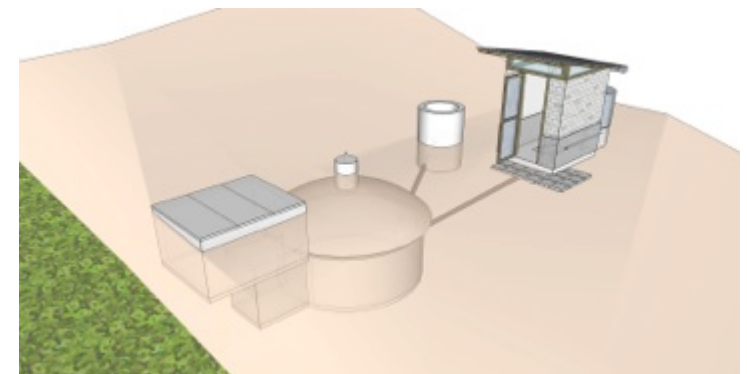

The current toilet and biogas components

Summary of the solutions from the architectural student team to develop a siting kit.

A. The siting principle flipcharts

The flipchart prototype drawings were used to assist CHDS discuss the key siting issues for the toilet and waste systems with village families. They provide an ordered way for CHDS staff to check all the key siting issues.

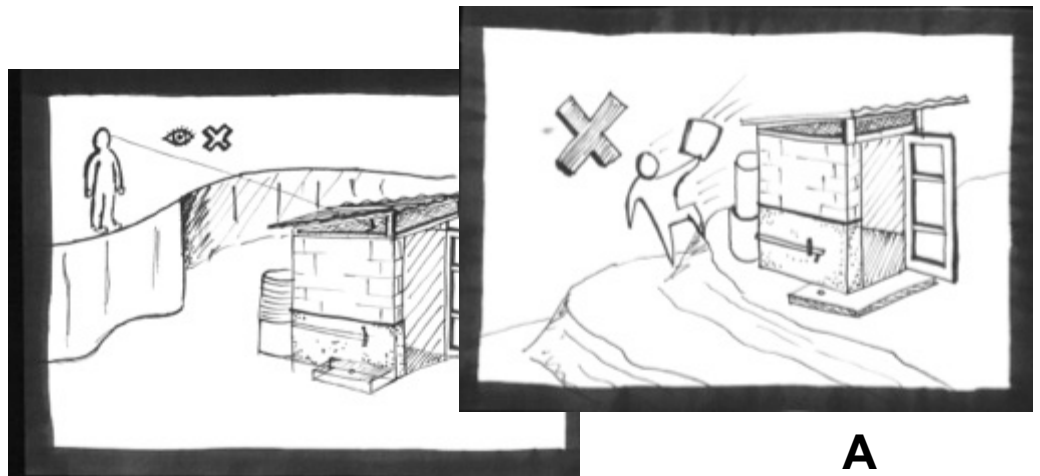

A

B. The model of the system parts

A prototype of a small, light, robust and portable model was developed to show families where the above ground and underground parts of the system could be located relative to their house. Each part of the model was colour coded to match the full size templates used to set out the systems.

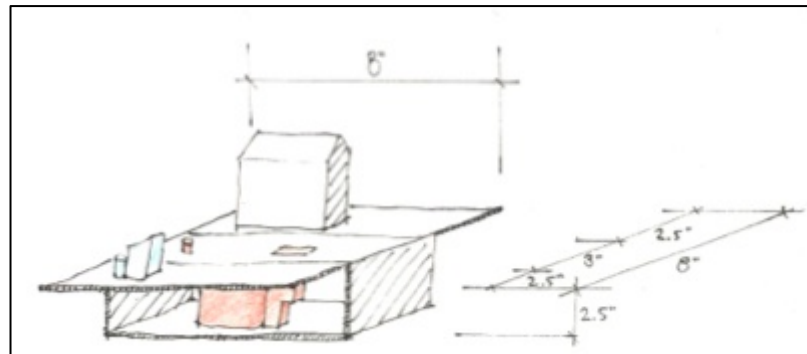

B

C. The full scale templates of the system components.

These were designed to help families understand the parts of the system and impact on their land, speed the process of CHDS setting out all parts of the toilet and waste treatment systems, and increase the accuracy of site pegging for excavation.



C

DETAILS OF THE ABOVE DESIGNS FOLLOW

The Siting Kit

A. The Flipcharts

These were designed to help CHDS to discuss important siting criteria with each village family

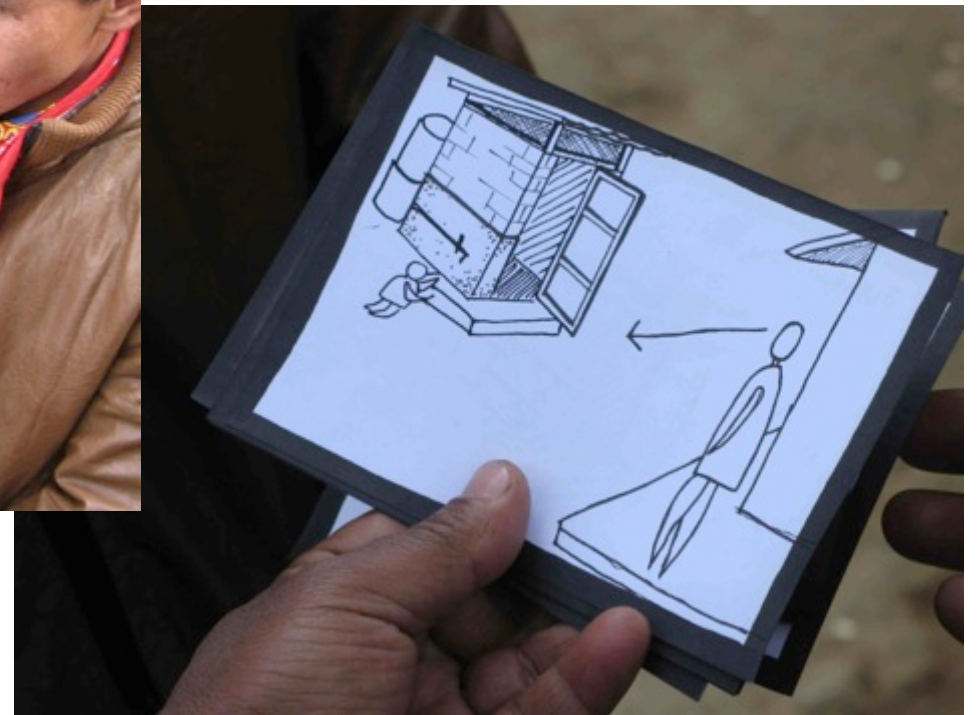

Examples of the Flipcharts

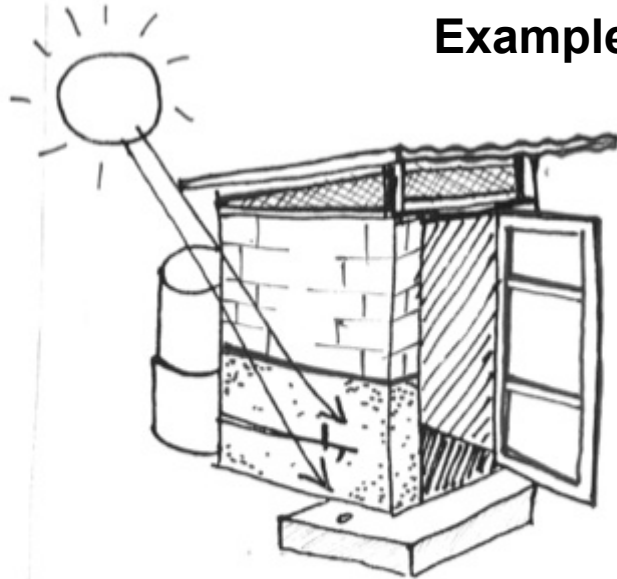

Sun helps dry and sterilise the wash pad area

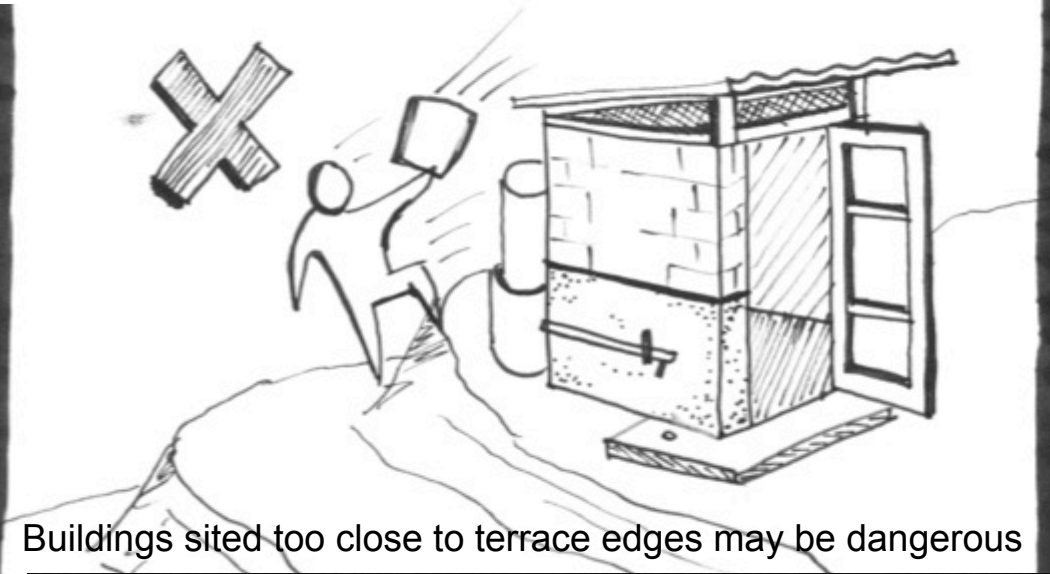

Buildings sited too close to terrace edges may be dangerous

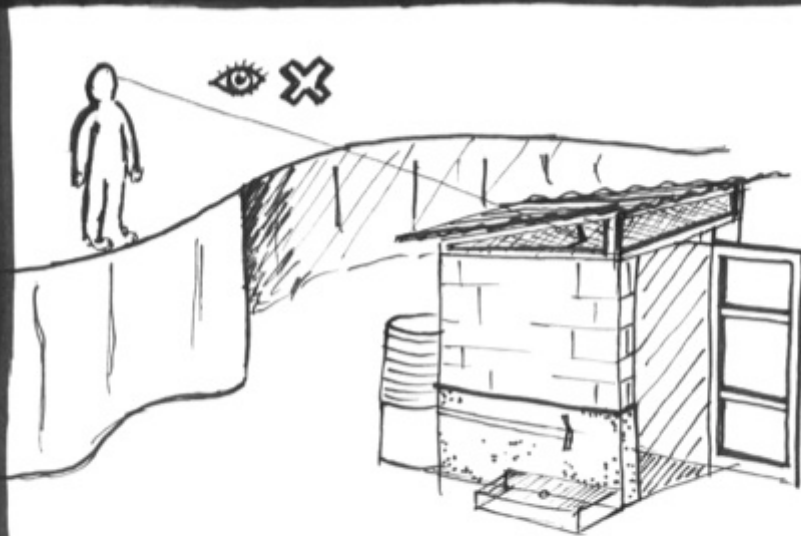

Overlooking through vent areas reduces privacy

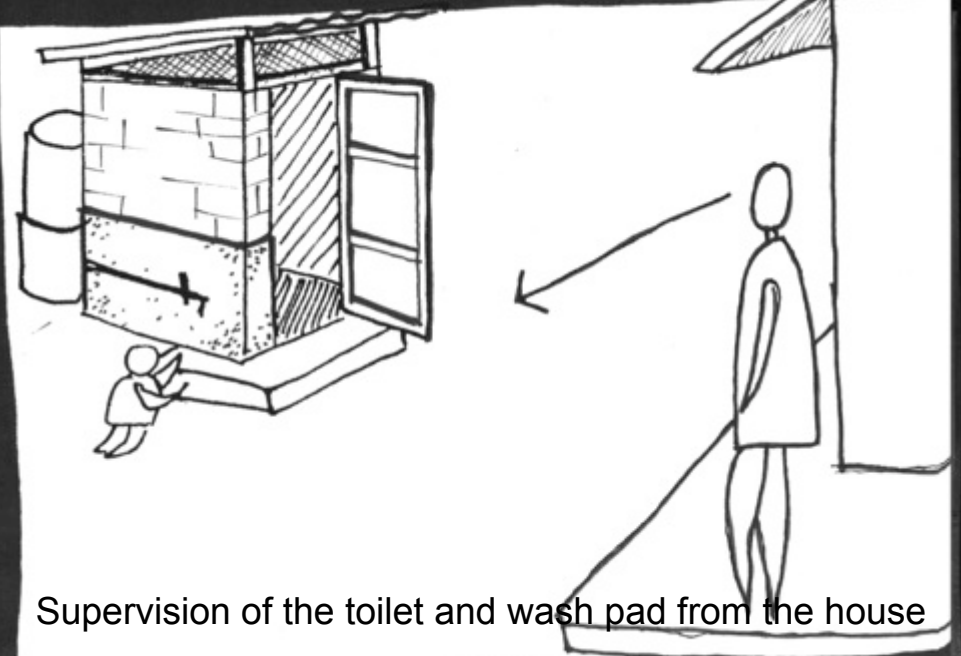

Supervision of the toilet and wash pad from the house

The Siting Kit

B. The model (prototype only)

This small model of the toilet and waste treatment system components, was designed to be used with the templates. Colour coded model parts help explain to family members how the system works and where the parts of the system (above and below ground) are located. A revised model, based on site experience, will be manufactured.

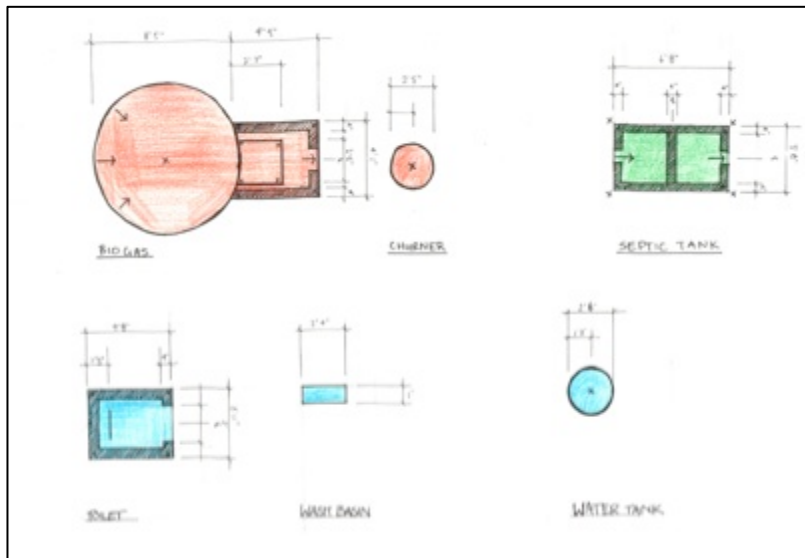
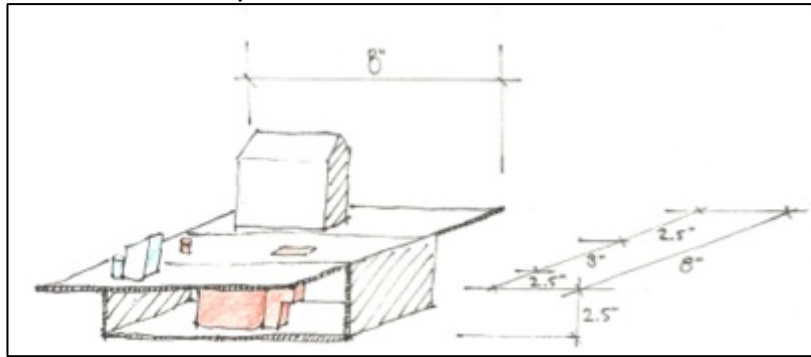

The Siting Kit

C. The Templates (plastic sheet and gaffer tape prototypes)

These were designed to help CHDS site the toilet components.

The previous method of siting components, using string and pegs, required the repeated measurement of each part on site and therefore was slow and difficult to adjust.

Full scale templates help in the siting process as follows:

- The full scale templates require no measurement on site to size the components
- Easy to move
- Clearly understood by the family and Village Sanitation Committee members
- Colour coded to the model
- Robust and re-useable
- Light
- When the final location is agreed, the templates provide the guide for all pegs to be located simply and accurately for excavation works and construction.

The temples were fabricated by the students with locally bought materials at the local hotel accommodation.



The siting kit templates: the family helps CHDS (Bishnu) adjust the location of the septic tank (white) after the toilet/wash pad and water tank (blue) have been located. NOTE: the gap in the black edging (walls) shows the door into the toilet.



The siting kit templates: the family helps adjust the location of the biogas digester (orange) and toilet building (blue)





The siting kit templates



The siting kit templates: after final agreement on the siting, students make a plan of the component location on each site and the family pegs each part of the system for future excavation work and construction.



The siting kit templates: after final agreement on the siting, students make a plan of the component location on each site and the family pegs each part of the system for future excavation work and construction.



The siting kit : final setout plan for house A13

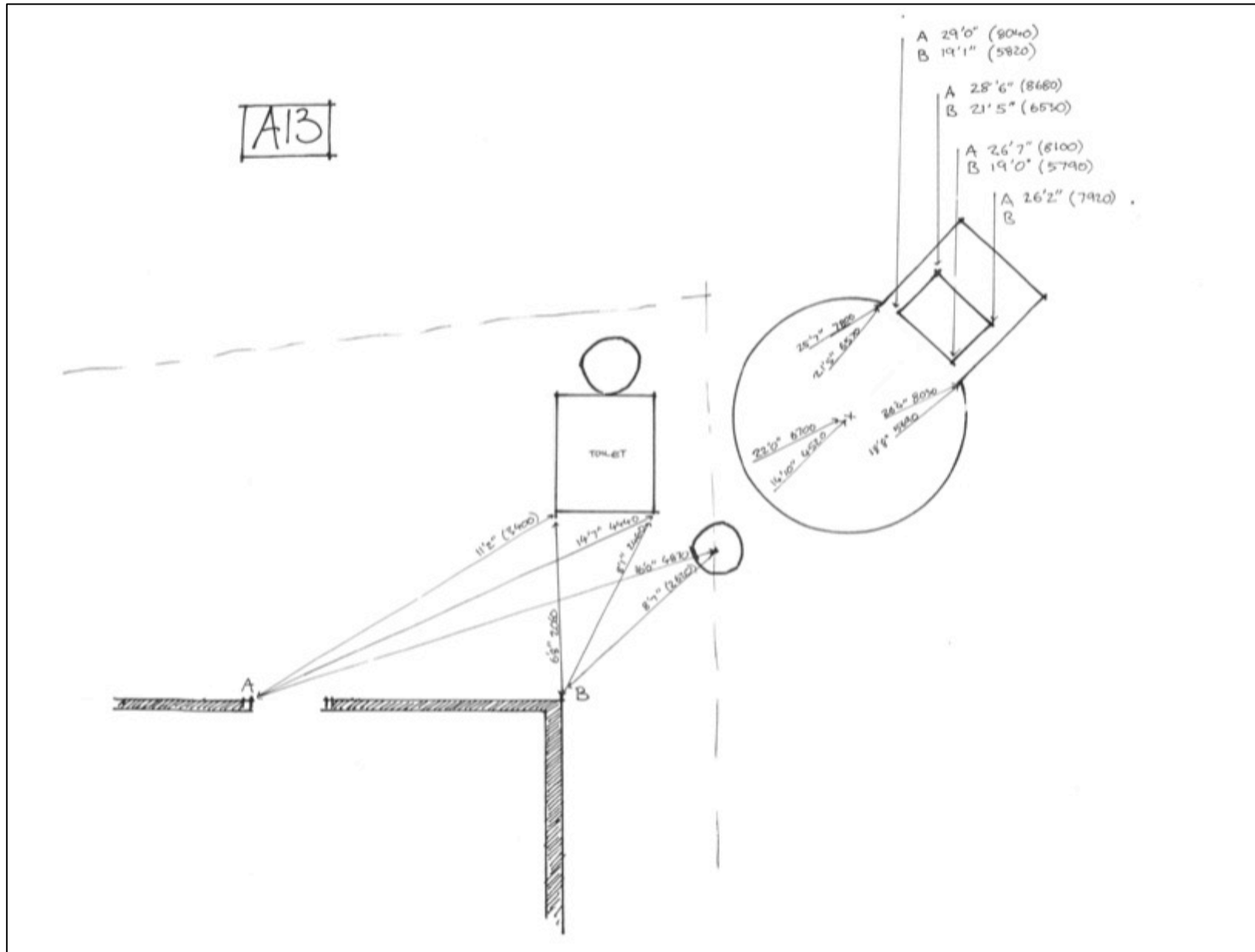

The siting kit : final setout plan for house A14

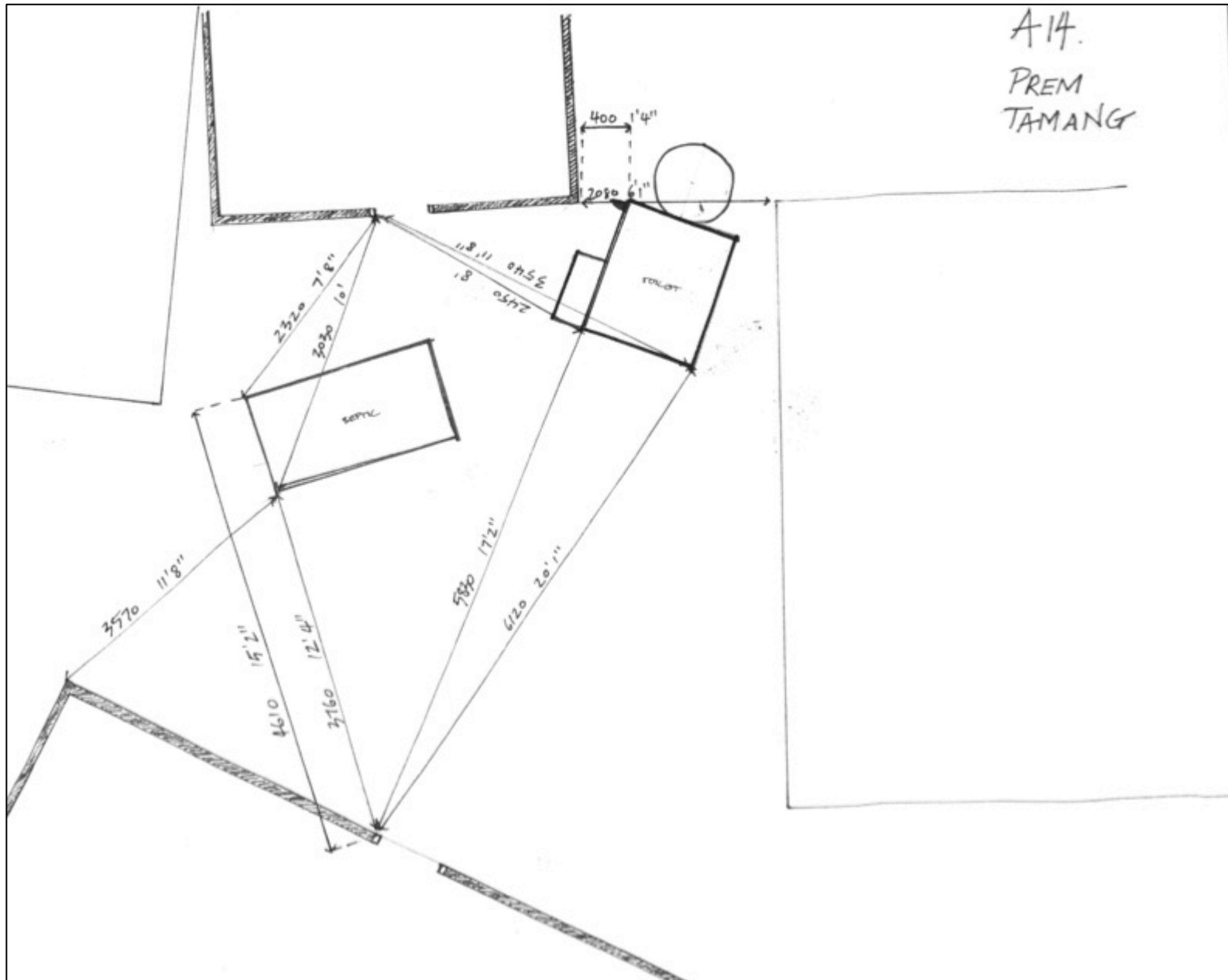

The siting kit : final setout plan for house A15

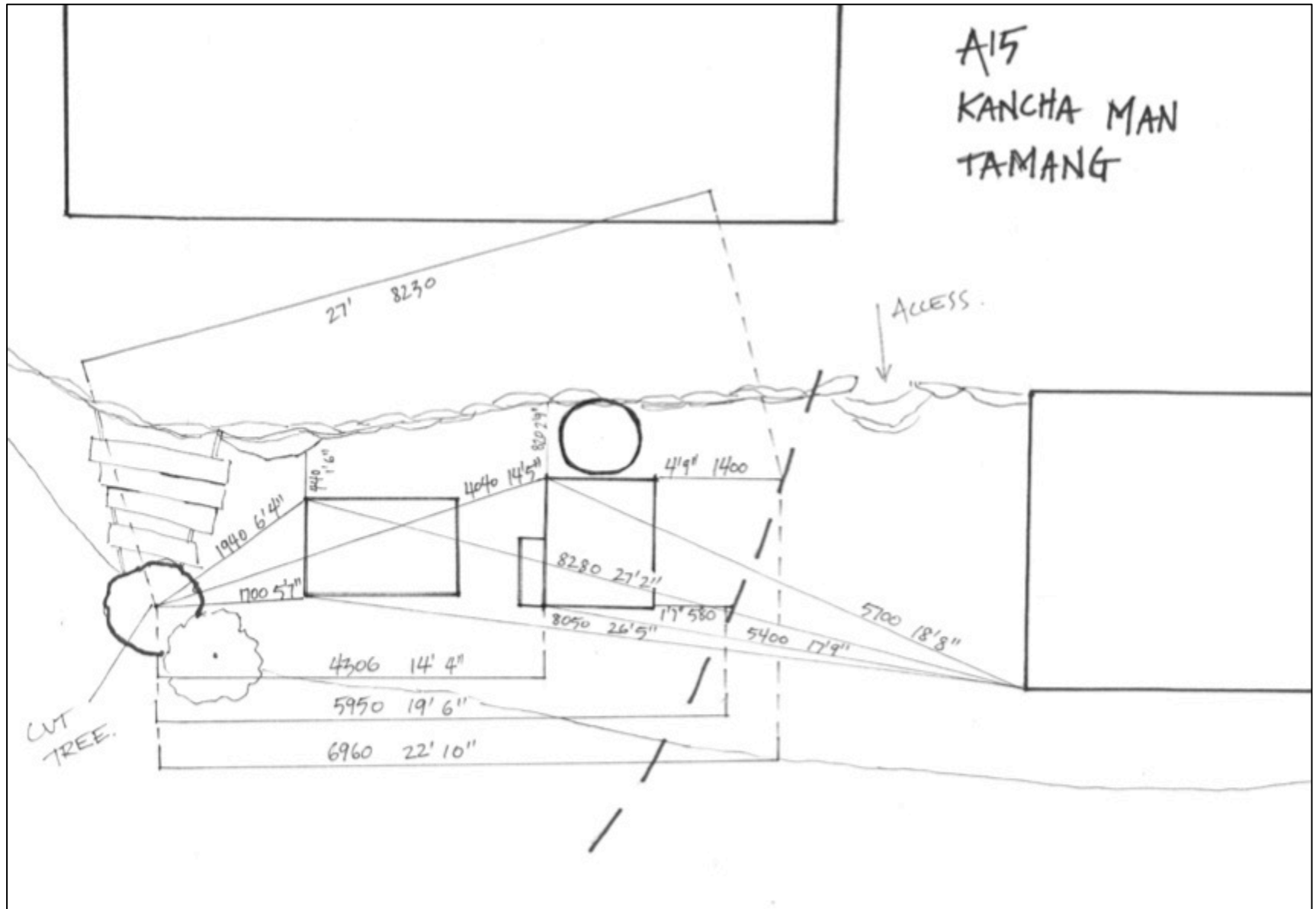

The siting kit : final setout plan for house A16

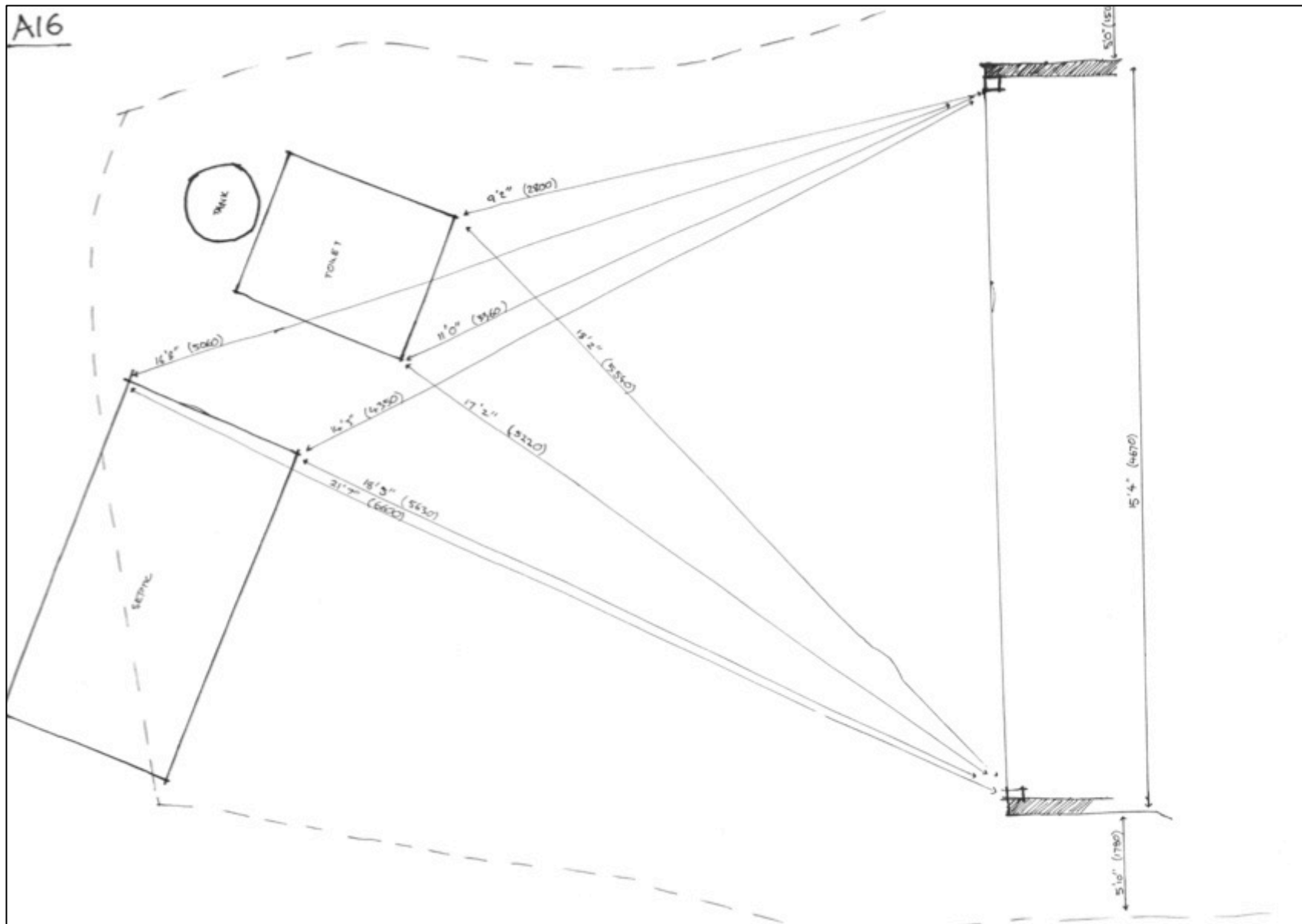

The siting kit : final setout plan for house A17

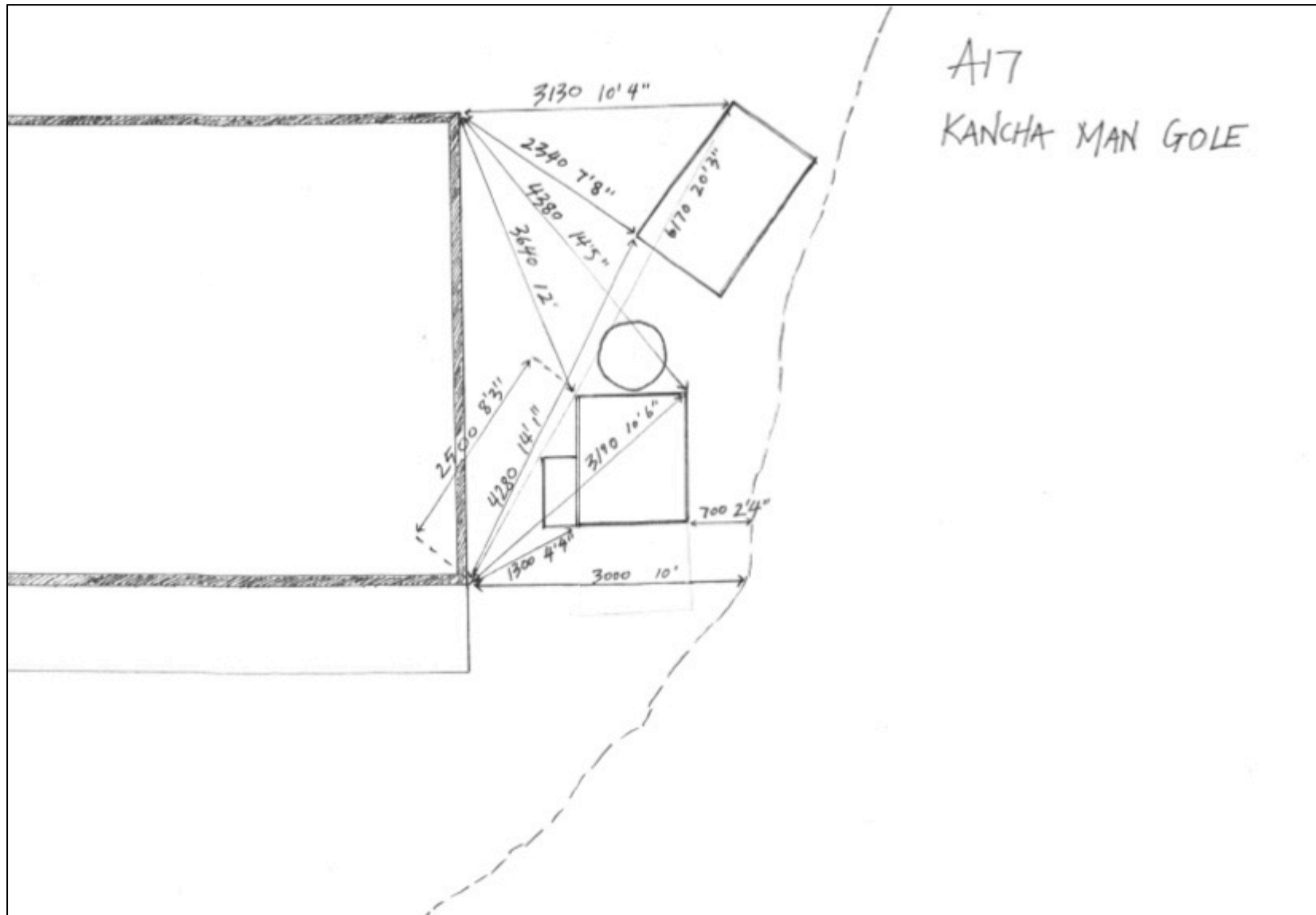

The siting kit : final setout plan for house A18

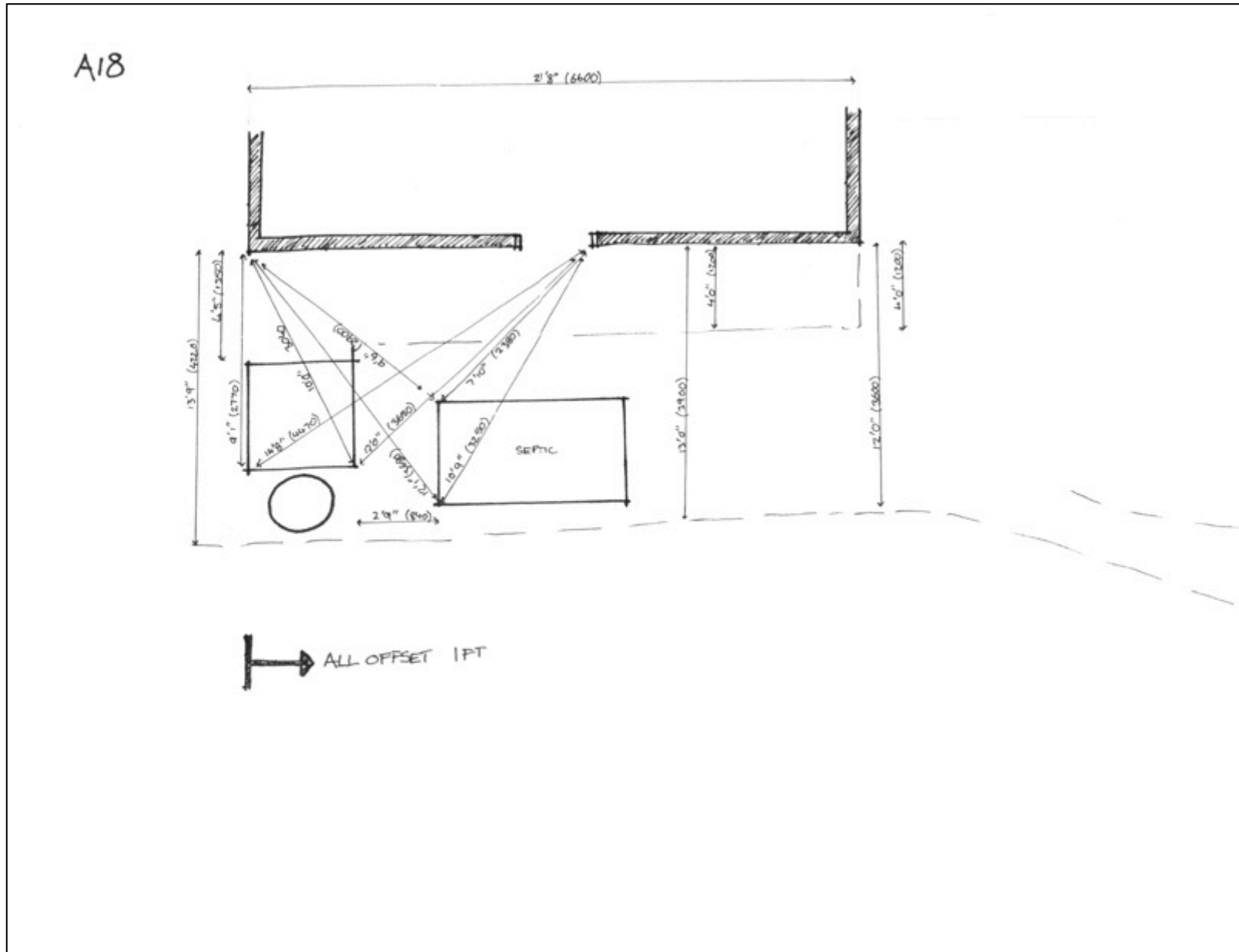

The siting kit : final setout plan for house A19

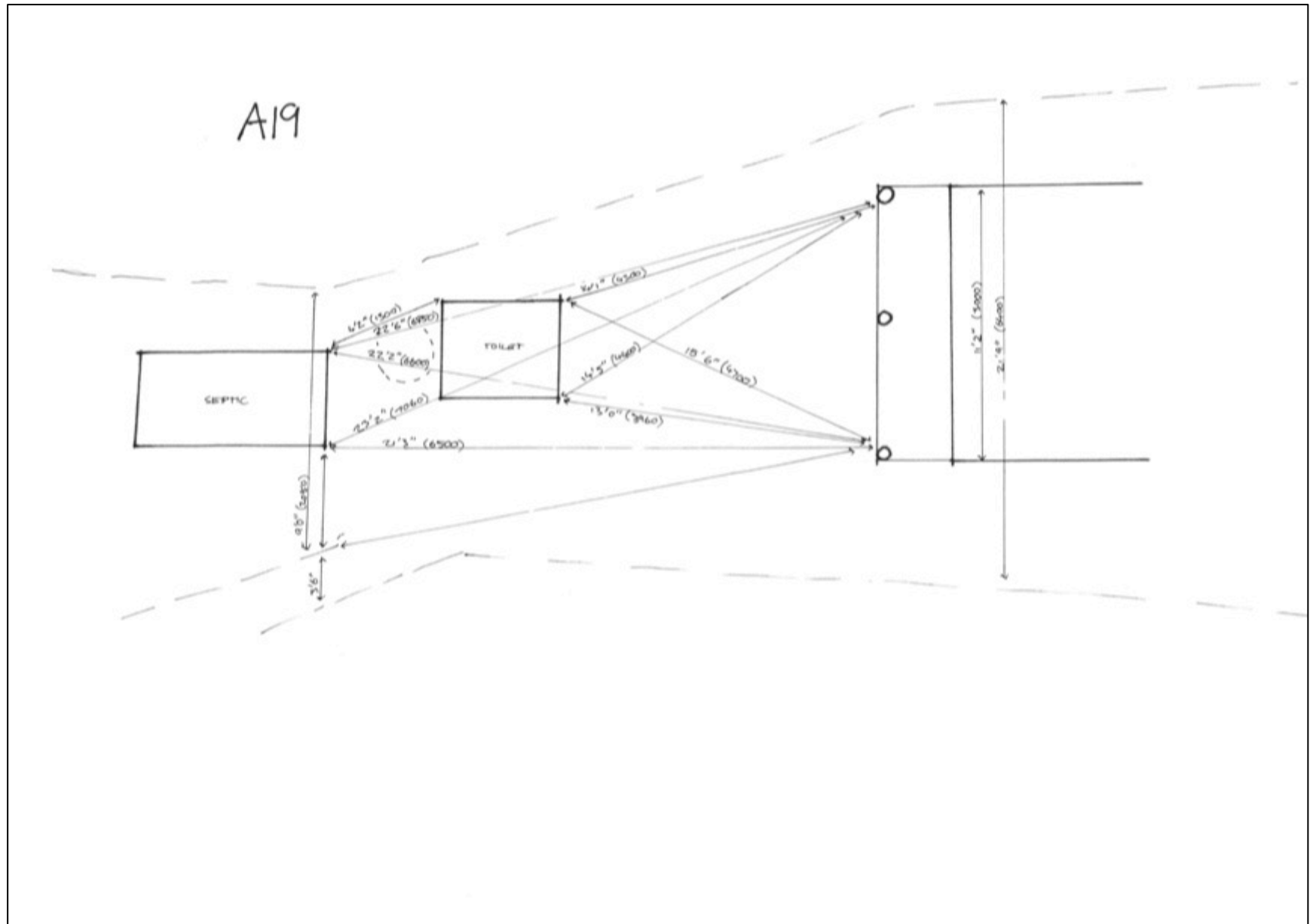

Summary of proposed future works as a result of the Sanitation Studio

The Siting Kit

A The siting principle flipcharts

The flipchart drawings will be slightly enlarged and text added to describe the issue on the reverse side of the card and the series will be laminated to protect the cards during field work

B The model of the system parts

The prototype will be remade by the students for sending back to Nepal in April. The remake will include;

- The same colour coding
- Perspex ground plane to see underground components
- Easier to unpack and repack

C The full scale templates of the system components

CHDS has agreed to use the plastic sheeting (original) templates as they are robust, easy to clean and not affected by wet ground.

They will undertake to remove the gaffer tape edging and replace with sewn on black edging indicating walls, flow etc. A bag to carry the templates model and flip charts will be found by CHDS.

The Plumbing works

A The 4 diverter valve options

On the next round of 15 toilets under construction between February and April (pre wet season) 7 Type B and 8 Type D will be fitted

Evaluation of all the type will occur during and after the wet season and the best designs fitted to the following rounds. CHDS will gather the cost information on each Type.

When the final types are agreed, the construction photos showing the details of the fabricating and fitting will be laminated and form part of the site kit of the construction team.

B The filler valve

This will be fitted to all of the next round of toilets as designed and fabricated.

C The wash pad

The formwork will be constructed (to HH produced detail drawings) and 1 unit will be constructed on the first toilet built in the next round. CHDS will calculate the cost of the wash pad. After the prototype is complete HH and CHDS will decide on how many will be constructed in the next round of toilets



Nepal Sanitation Studio 2013

www.healthabitat.com